

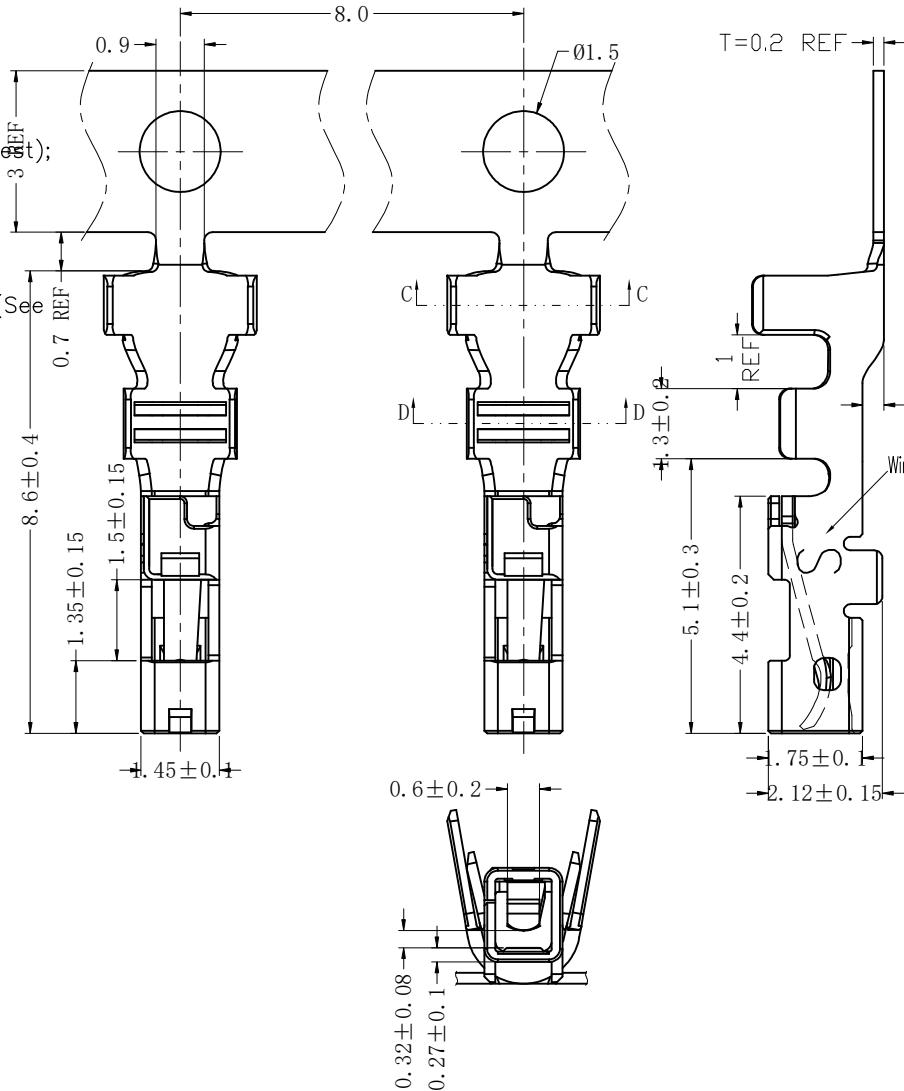

- NOTES:
- 1.Current Rating:1.5A Max(28AWG Terminal);
  - 2.Contact Resistance: 20mΩ Max;
  - 3.Operating Temperature: -40°C to +125°C;
  - 4.Contact Material: Copper Alloy;
  - 5.Contact plating:  
S4: 15μ" Gold on contact area (See ordering information),  
50μ" Nickel underplating overall;
  - 6.Wire Size Range:28-30AWG;
  - 7.Insulation range:1.2-0.6mm;

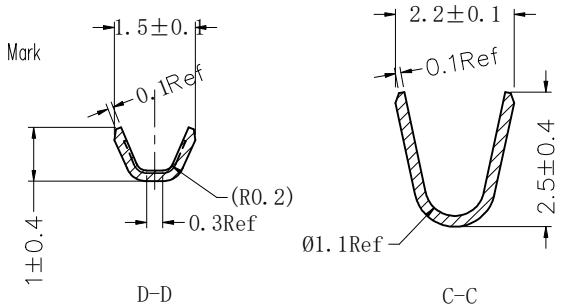

SCHEMATIC DIAGRAM OF TERMINAL DISCHARGE

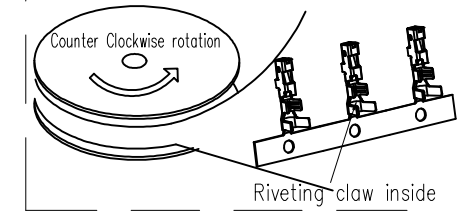

Ordering Information

WD3500-3TP30S401

3=Cutting + Electroplate+Forming

Terminal

Material: P=C5191

Wire Size Range: 28-30AWG

Contact Plating: S4=15μ" Gold/Ni

WCON internal code

Crimping size of wire terminals for reference

Wire Size (AWG)	Required Crimping Size at Wire Barrel		Required Crimping Size at Insulation Barrel	
	Width(+/-0.05mm)	Height(+/-0.05mm)	Width(+/-0.05mm)	Height(+/-0.05mm)
28AWG	1.25	0.55	1.35MAX	1.70MAX
30AWG	1.25	0.50	1.35MAX	1.70MAX

REV	DATE	MODIFICATION DESCRIPTION	CHANGE	OPERATION		DRAW	DATE	SCALE	FIT	PART NO.	TITLE	WCON	
				X.X	±0.40							kevin-xin	2021.09.25
A1	2023.06.05	Increase schematic	---	X.XX	±0.25	CHECK	DATE	SIZE	A4	WD3500-3TP30S401	Crimp Terminal (28-30AWG)	WCON-Dongguan	WCON-Kunshan
A0	2021.09.25	NEW	---	X.XXX	±0.15	APPROVE	DATE	SHEET	1/1	Plating-Gold	Customer NO.	Tel: +86 769 85358920	Tel: +86 512 57468408
REV	DATE	MODIFICATION DESCRIPTION	CHANGE	Angle	± 3'			DIM	TOL	PROJ.			



Http: www.wcon.com

WCON-Dongguan  
Tel: +86 769 85358920  
Fax: +86 769 85358915  
E-mail: sales@wcon.com

WCON-Kunshan  
Tel: +86 512 57468408  
Fax: +86 512 57468468  
E-mail: salesks@wcon.com