

HSF

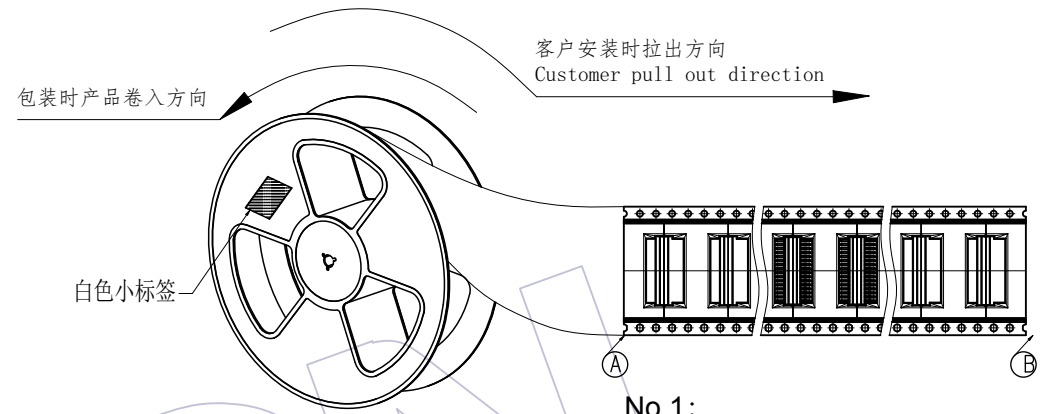

No.1:
产品包装前,注意载带要留空160mm以上
将产品放入载带凹槽后,用盖带封装,
注意:盖带与承载带的拉力30g-120g

PIN	载带料号	W	S	F	PCS/Reel	PCS/内箱	PCS/外箱
2	TR1537-M1002Z03201	16.0±0.30	/	7.50±0.15	1000	4000	12000
3	TR1537-M1003Z03201	16.0±0.30	/	7.50±0.15	1000	4000	12000
4	TR1537-M1004Z03201	16.0±0.30	/	7.50±0.15	1000	4000	12000
5	TR1537-M1005Z03201	16.0±0.30	/	7.50±0.15	1000	4000	12000
6	TR1537-M1006Z03201	16.0±0.30	/	7.50±0.15	1000	4000	12000
7	TR1537-M1007Z03201	16.0±0.30	/	7.50±0.15	1000	4000	12000
8	TR1537-M1008Z03201	24.0±0.30	/	11.50±0.15	1000	3000	9000
9	TR1537-M1009Z03201	24.0±0.30	/	11.50±0.15	1000	3000	9000
10	TR1537-M1010Z03201	24.0±0.30	/	11.50±0.15	1000	3000	9000
11	TR1537-M1011Z03201	24.0±0.30	/	11.50±0.15	1000	3000	9000
12	TR1537-112N2401	24.0±0.30	/	11.50±0.15	1000	3000	9000
13	TR1537-M1013Z03201	24.0±0.30	/	11.50±0.15	1000	3000	9000
14	TR1537-M1014Z03201	24.0±0.30	/	11.50±0.15	1000	3000	9000
15	TR1537-M1015Z03201	24.0±0.30	/	11.50±0.15	1000	3000	9000
16	TR1537-M1016Z03201	32.0±0.30	28.40±0.15	14.20±0.15	1000	2000	6000
17	TR1537-M1017Z03201	32.0±0.30	28.40±0.15	14.20±0.15	1000	2000	6000
18	TR1537-M1018Z03201	32.0±0.30	28.40±0.15	14.20±0.15	1000	2000	6000
19	TR1537-M1019Z03201	32.0±0.30	28.40±0.15	14.20±0.15	1000	2000	6000
20	TR1537-M1020Z03201	32.0±0.30	28.40±0.15	14.20±0.15	1000	2000	6000
21	TR1537-M1021Z03201	44.0±0.30	40.40±0.15	20.20±0.15	1000	2000	6000
22	TR1537-M1022Z03201	44.0±0.30	40.40±0.15	20.20±0.15	1000	2000	6000
23	TR1537-M1023Z03201	44.0±0.30	40.40±0.15	20.20±0.15	1000	2000	6000
24	TR1537-M1024Z03201	44.0±0.30	40.40±0.15	20.20±0.15	1000	2000	6000
25	TR1537-M1025Z03201	44.0±0.30	40.40±0.15	20.20±0.15	1000	2000	6000
30	TR1537-M1030Z03201	44.0±0.30	40.40±0.15	20.20±0.15	1000	2000	6000
40	TR1537-M1040Z03201	56.0±0.30	52.40±0.15	26.20±0.15	1000	1000	3000
50	TR1537-M1050Z03201	72.0±0.30	68.40±0.15	34.20±0.15	1000	1000	3000

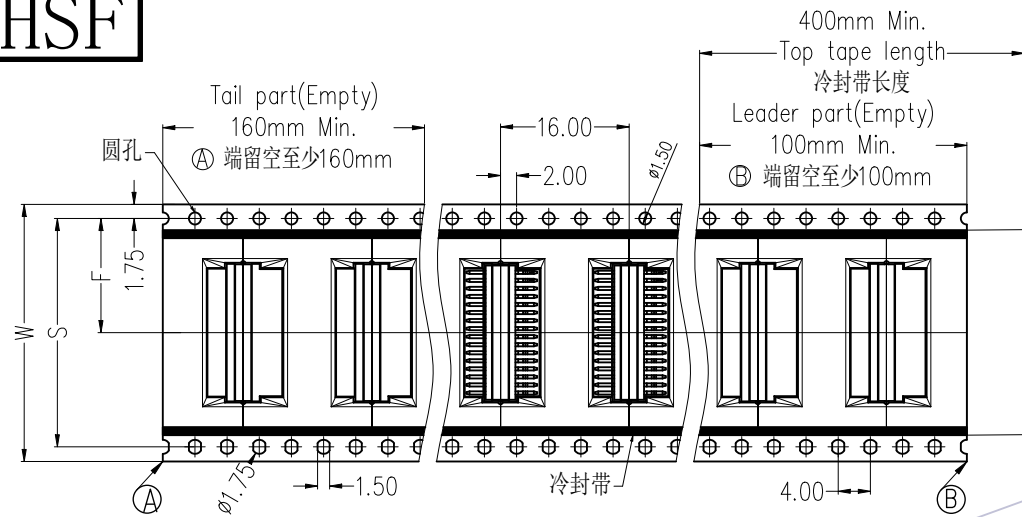
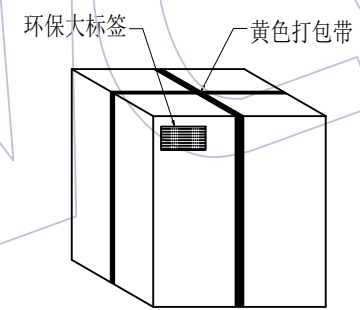

外箱: CTN-18K

No.4:
封箱, 打包, 贴标签。

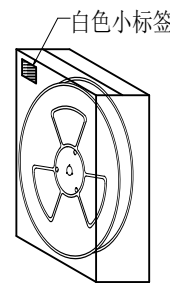
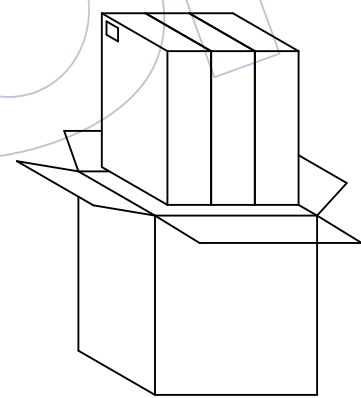

内箱: CTN-18E

No.3:
将内箱装入外箱(3内箱/外箱)
注意统一标签方向

No.2:
将卷盘套上PE-32防水袋,
放入1包干燥剂,
真空机封口后装入内箱,
用封箱胶封装好,并贴上标签。

变更记事

版次	日期	变更说明	变更	核准
REV	DATE	MODIFICATION DESCRIPTION	CHANGE	APPROVE
A0	2021/03/01	NEW	-----	-----

工程图	绘图	苏 珊	2021/03/01	SCALE	FIT
ENGINEERING	DRAW				
X.X	±0.30	设计		UNIT	mm
X.XX	±0.20	DESIGN		SIZE	A4
X.XXX	±0.10	审核		SHEET	1/1
Angle	± 2°	CHECK		PROJ.	☉
DIM	TOL	核准			
		APPROVE			

料号 PART NO.		1537-11XXXXZ091CRXX	
		品名 TITLE:	
		1.00mm PH,1*XXP,R/A&SMT,W/T Post	
		H=3.7.L=9.1/2.7/2.4 卷装规范	

WCON
WCON ELECTRONICS (GUANGDONG) CO., LTD