

HSF

NOTES:
 Rated Current: 15 AMP
 Contact Resistance: 8 mΩ Max
 Withstand Voltage: 2000 V AC/DC
 Insulation Resistance: 1000 MΩ min
 Operation Temperature: -40°C to +105°C
 Wire Range: 30~12 AWG
 Wire Strip Length: 7 mm
 Screw Counter Torsion Force: 4.4 lbf.in Min.

2P Without RAMP Locking "A"

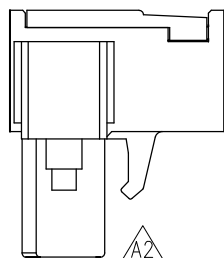

W/O WCON LOGO

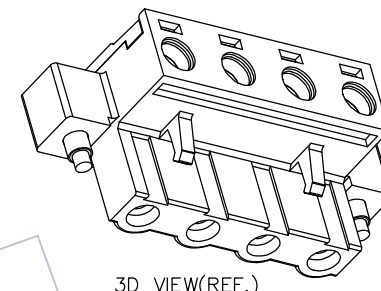
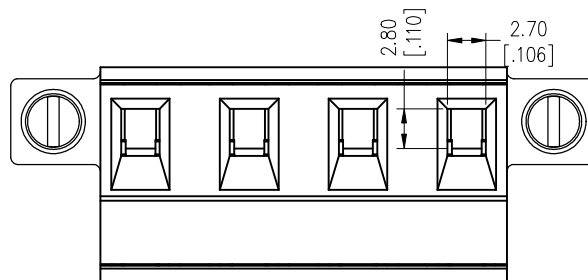

3D VIEW(REF.)

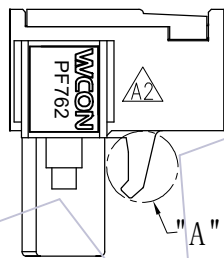

W/T WCON LOGO

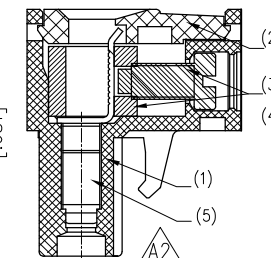
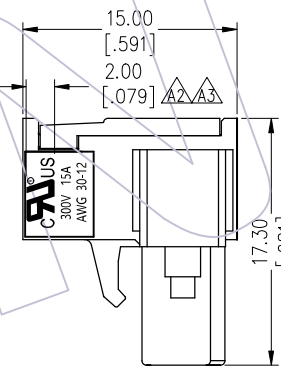
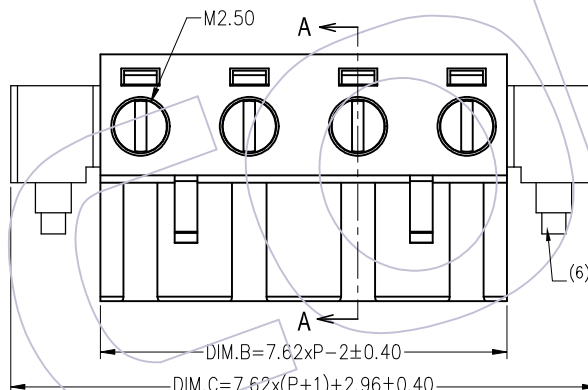

SECTION A-A

Ordering Information:

P F 762 - C XX A SM W 1 N

F=Female Pitch 762=7.62 No. of Pins 02-20P Contact Plated SM=Matte Tin Blank=W/T WCON Logo N=W/O WCON Logo
 Color Type
 A=Green N=W/T Two Side Screw

PIN	DIM.A	DIM.B	DIM.C	DIM.D	PIN	DIM.A	DIM.B	DIM.C	DIM.D
02	7.62	13.24	25.82	—	12	83.82	89.44	102.02	77.44
03	15.24	20.86	33.44	8.86	13	91.44	97.06	109.64	85.06
04	22.86	28.48	41.06	16.48	14	99.06	104.68	117.26	92.68
05	30.48	36.10	48.68	24.10	15	106.68	112.30	124.88	100.3
06	38.10	43.72	56.30	31.72	16	114.30	119.92	132.50	107.92
07	45.72	51.34	63.92	39.34	17	121.92	127.54	140.12	115.54
08	53.34	58.96	71.54	46.96	18	129.54	135.16	147.74	123.16
09	60.96	66.58	79.16	54.58	19	137.16	142.78	155.36	130.78
10	68.58	74.20	86.78	62.20	20	144.78	150.40	162.98	138.40
11	76.20	81.82	94.40	69.82					

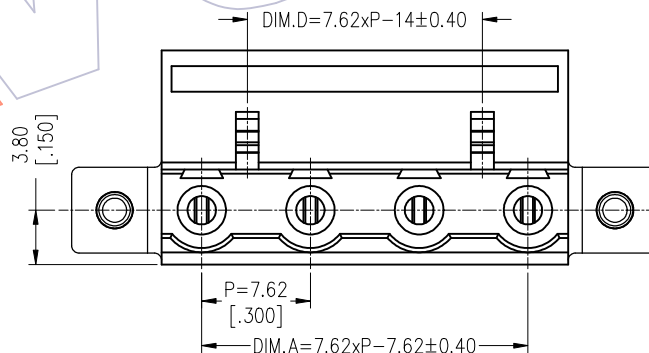

ITEM	TITLE	P/N	Q'TY	Material
(6)	Screw-2	MC025-1SXX01	2	C1018
(5)	Contact	TPT051-PSM002	N	C5191R-H T=0.4
(4)	Pin Block	BL025-1SN101	N	C3604
(3)	Screw	MA025-1SXX01	N	C1018
(2)	Cover	HPC762-XXB1AN1	1	PA66 UL94-V0
(1)	Housing	HPF762-XXB1AW1(N)	1	PA66 UL94-V0

REV	DATE	MODIFICATION DESCRIPTION	CHANGE	OPERATION	DRAW	DATE	SCALE	FIT	PART NO.
A3	2020/10/07	Modify UL Logo	A3	XSR	OPERATION	2020/10/07	UNIT	mm	PF762-CXXASMW1(N) A2
A2	2020/08/05	ADD LOGO; ADD W/O WCON LOGO P/N	A2	XSR	CHECK	DATE	SIZE	inch	TITLE:
A1	2015/07/15	Modify	A1	Allen	APPROVE	DATE	SHEET	A4	7.62mm Pitch Female Pluggable Terminal Blocks
A0	2013/07/17	NEW	—	—	PROJ.	DATE	1/1	Customer NO.	
				Angle ± 3°					
				DIM TOL					

WCON
 Http: www.wcon.com

WCON-Dongguan Tel: +86 769 85358920 Fax: +86 769 85358915 E-mail: sales@wcon.com

WCON-Kunshan Tel: +86 512 57468408 Fax: +86 512 57468468 E-mail: salesks@wcon.com