

HSF

NOTES:

Current Rating:10A
 Voltage Rating:300V
 Contact Resistance:8milliohm Max
 Withstand Voltage:AC2000V
 Insulation Resistance:1000Megohm Min
 Operation Temperature:-40°C to +105°C

Housing Material:PA66+30%GF(UL94V-0) $\Delta 2$
 Contact Material:Brass

Ordering Information:

P M 508 - 1 R XX X SM 1 N

M=Male Pitch 508=5.08
 Color A=Green B=Black G=Grey
 No. of Pins 02-24P
 Contact Plated SM=Matte Tin
 Blank=W/T-WCON N=W/O WCON

13P	68.04 ±0.30	60.96 ±0.30			
12P	62.96 ±0.30	55.88 ±0.30	24P	123.92 ±0.50	116.84 ±0.50
11P	57.88 ±0.30	50.80 ±0.30	23P	118.84 ±0.50	111.76 ±0.50
10P	52.80 ±0.30	45.72 ±0.30	22P	113.76 ±0.50	106.68 ±0.50
9P	47.72 ±0.30	40.64 ±0.30	21P	108.68 ±0.50	101.60 ±0.50
8P	42.64 ±0.30	35.56 ±0.30	20P	103.60 ±0.50	96.52 ±0.50
7P	37.56 ±0.20	30.48 ±0.20	19P	98.52 ±0.40	91.44 ±0.40
6P	32.48 ±0.20	25.40 ±0.20	18P	93.44 ±0.40	86.36 ±0.40
5P	27.40 ±0.20	20.32 ±0.20	17P	88.36 ±0.40	81.28 ±0.40
4P	22.32 ±0.20	15.24 ±0.20	16P	83.28 ±0.40	76.20 ±0.40
3P	17.24 ±0.20	10.16 ±0.20	15P	78.20 ±0.40	71.12 ±0.40
2P	12.16 ±0.20	5.08 ±0.10	14P	73.12 ±0.40	66.04 ±0.40
PIN	A	B	PIN	A	B

ITEM	Pitch	Mating
Standard	508	PF508
Alternate		

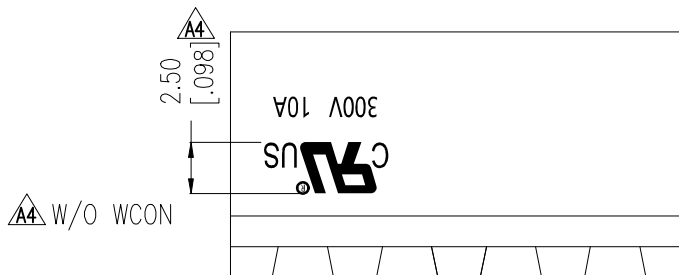

$\Delta 4$ W/O WCON

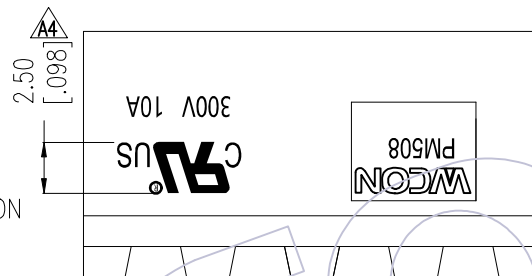

W/T WCON

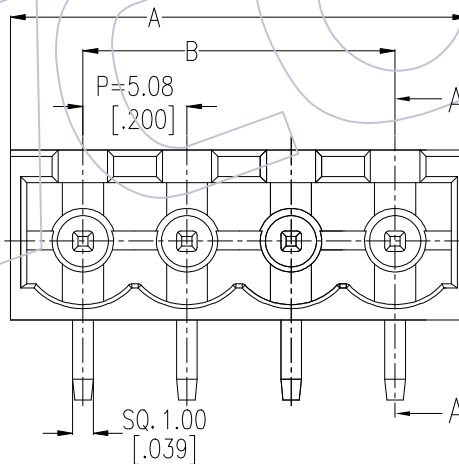

Recommended P.C.B Layout(Top Side)
 (PCB BOARD TOLERANCE±0.05)

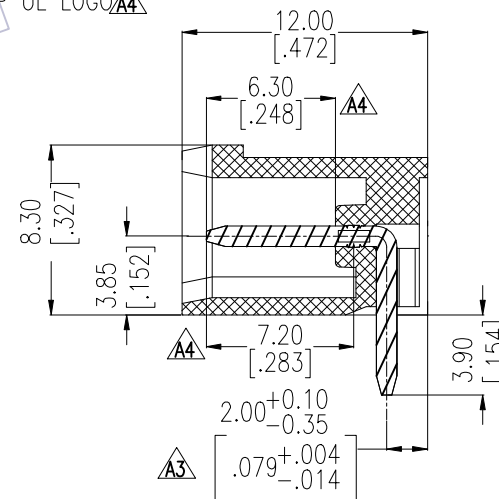
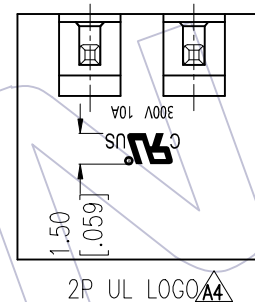
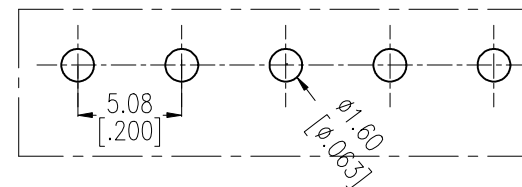

SECTION A-A

A4	2020/11/18	ADD UL LOGO & DIM; ADD W/O WCON SPEC & P/N;	$\Delta 4$	XSR	OPERATION	DRAW	DATE	SCALE	FIT	PART NO.
A3	2017/12/29	Modify DIM. 2.0±0.2 to 2.0±0.15	$\Delta 3$	XSR	x.x ±0.40	XSR	2020/11/18	UNIT	mm	PM508-1RXXSM1(N) $\Delta 1$ $\Delta 4$
A2	2013/06/05	Modify The Housing Material	$\Delta 2$	XSR	x.xx ±0.25	CHECK	DATE	SIZE	A4	TITLE:
A0	2011/06/08	NEW			x.xxx ±0.15	APPROVE	DATE	SHEET	1/1	5.08mm Pitch Male Pluggable Terminal Blocks
REV	DATE	MODIFICATION DESCRIPTION	CHANGE		Angle ± 3°			PROJ.		Customer NO.
					DIM TOL					

WCON

Http: www.wcon.com

WCON-Dongguan Tel: +86 769 85358920 Fax: +86 769 85358915 E-mail: sales@wcon.com
 WCON-Kunshan Tel: +86 512 57468408 Fax: +86 512 57468468 E-mail: sales@wcon.com