

HSF

IDC CONNECTOR SPEC.:

Insulation Material: PBT+30%GF(UL94V-0)
 Contact Material: Phosphor Bronze
 Contact plating: Au Over Ni

SPECIFICATIONS

Insulation Resistance: 5MΩ Min
 Contact Resistance: 1.0Ω Max
 Withstand Voltage: AC 300V, 10S
 The Cable Assembly Must 100% Test

CABLE MATERIAL

Insulation: UL 2651, Grey Red Side
 Conductor: 28AWG(7/0.12mm)
 Electrical: 300V

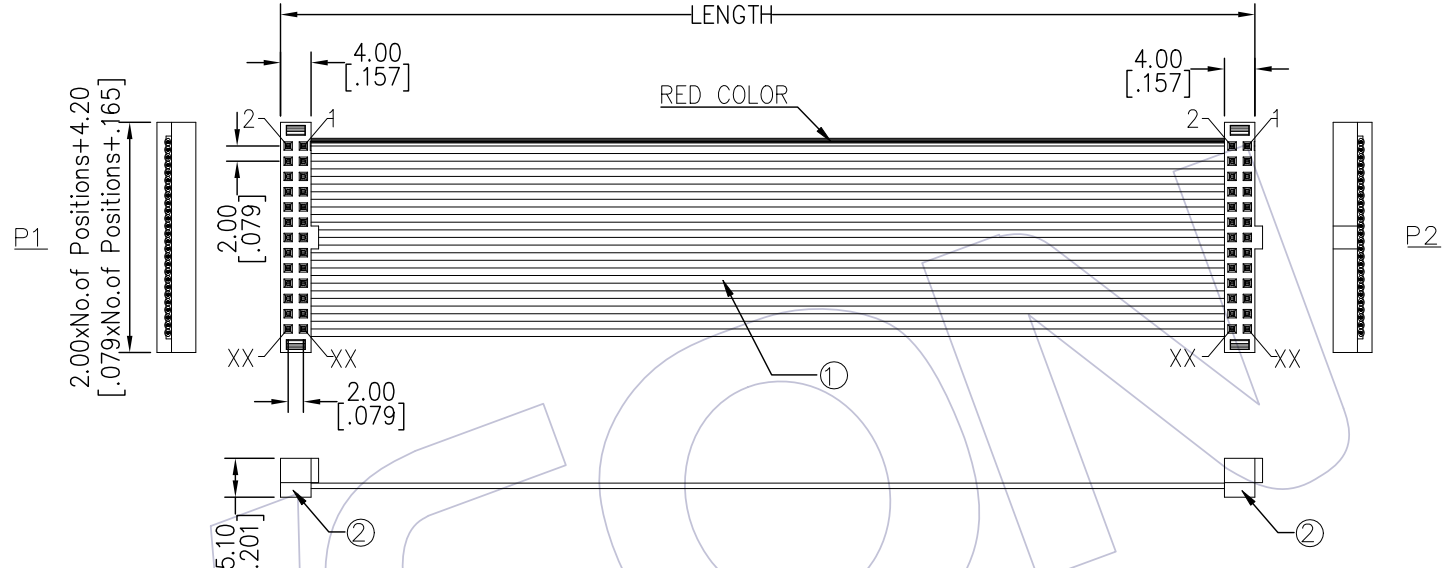

Ordering Information

FA22 - XX XX A A B XXX - 71

No. OF Pins
06-64p

Contact Plating:
 G0=Gold Flash
 G3=10u"Gold
 G4=15u"Gold
 G5=30u"Gold
 S0=Gold Flash/Ni
 S3=10u"Gold/Ni
 S4=15u"Gold/Ni
 S5=30u"Gold/Ni
 SN=Tin

Connector Direction:
 A=Same Direction

Connector Color:
 B=Black

Length of Line(mm)

CONNECT METHOD

P1	Color	P2
1	Red	1
2	Grey	2
3	Grey	3
4	Grey	4
XX	Grey	XX
XX	Grey	XX

LENGTH	TOLERANCE
≤100	±5
101~1000	±10
1001~3000	±20
3001~	± Lx1%

②	5225-XXUPXXBW01	CONN.	2.00 S-Type IDC XXP Black Phosphor Bronze Plating Xu" gold With Bump	2	PCS
①	F1U-B28GXDO-XXXX-1	WIRE	UL2651 PH1.0mm XXP 28AWG(7/0.12TC) PVC Grey Marking Red Side	XXX	MM
NO.	PART NO.	NAME	TITLE	QTY	UNIT

OPERATION	DRAW	DATE	SCALE	FIT	PART NO.
x.x ±0.40	BEN	2011/08/27	UNIT mm		FA22-XXXXAABXXX-71
x.xx ±0.25	CHECK	DATE	SIZE A4		TITLE: 2.0 S-Type IDC XXP Drawing
x.xxx ±0.15	APPROVE	DATE	SHEET 1/1		Customer NO.
Angle ± 3°			PROJ.		
DIM TOL					

WCON
 Http: www.wcon.com

WCON-Dongguan
 Tel: +86 769 85358920
 Fax: +86 769 85358915
 E-mail: sales@wcon.com

WCON-Kunshan
 Tel: +86 512 57468408
 Fax: +86 512 57468468
 E-mail: salesks@wcon.com

REV	DATE	MODIFICATION DESCRIPTION	CHANGE
A1	2020/03/10	Modify Drawing	XSR
A0	2011/08/27	NEW	-----