

HSF

NOTES:
 Current Rating: 3.0AMP
 Voltage Rating: 250V
 Contact Resistance: 20mΩ Max
 Withstand Voltage: 775V AC
 Insulation Resistance: 1000MΩ Min
 Operation Temperature: -55℃ to +105℃
 Contact Material: Copper alloy
 Contact plating:
 XXu" Glod on contact area(See ordering information).
 100u"Matte-Tin on solder area.
 50u"Nickel underplating overall.
 Insulator Material:LCP UL94V-0(Std)
 IR solidering,Peak temperature: 260±5℃, 5s

Ordering Information

3600 - S XXX - 085 M XX X 01

TYPE S:Socket	Internal Code
No.of Pins(Total) 010:10PIN (02-60Pin)	Packing: T:Tube R:Tape&Reel
Insulator Height 085:8.51mm	Contact Plating: W0=Gold Flash/Matte Tin W3=10u" Gold/Matte Tin W5=30u" Gold/Matte Tin
Contact Shape M:SMT	

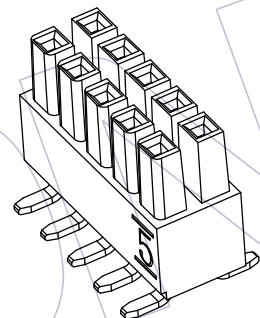
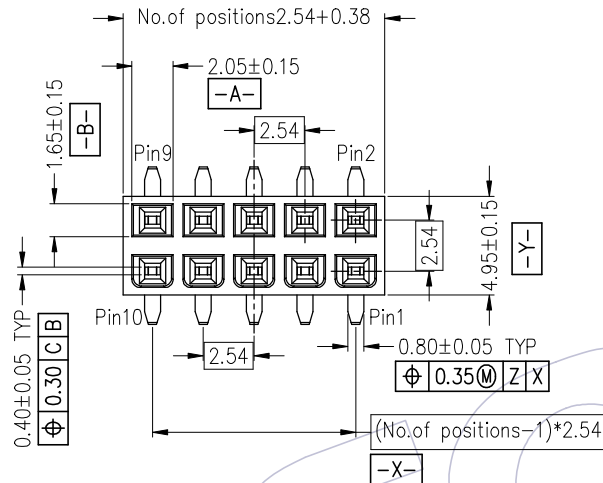

Recommended P.C.B layout(Top Side)
 (PCB BOARD TOLERANCE±0.05)

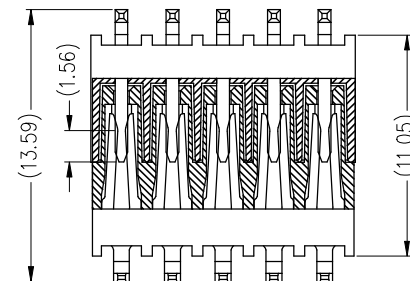
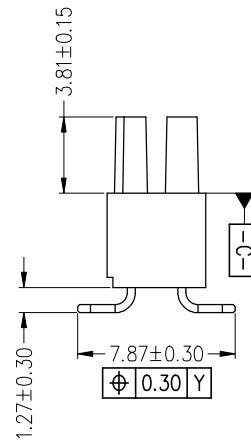
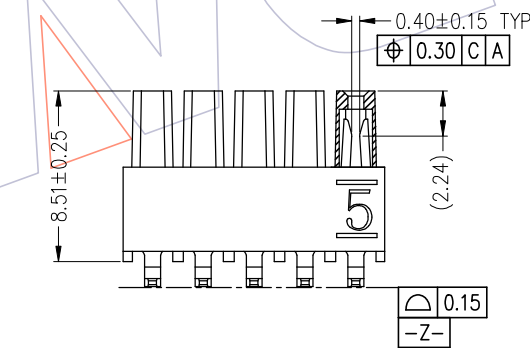
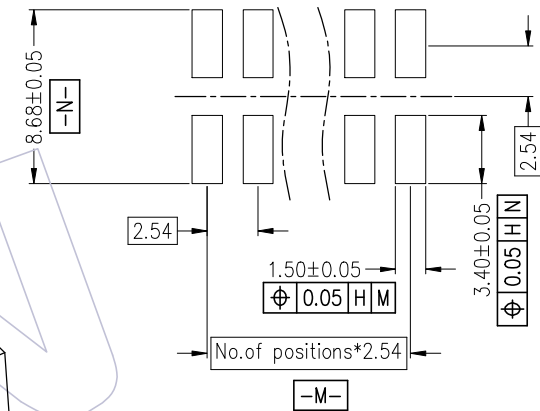

Female&Male mating

				OPERATION	DRAW	DATE	SCALE	FIT	PART NO.
				x.x ±0.40	Bruce	2020/05/12	UNIT	mm	3600-SXXX-085MXXX01
				x.xx ±0.35	CHECK	DATE	SIZE	A4	TITLE:
AO	2020/05/12	NEW	-----	x.xxx ±0.15	APPROVE	DATE	SHEET	1/2	2.54mm Board to Board Conn., "S" Type,Socket,SMT,H=6.35mm
REV	DATE	MODIFICATION DESCRIPTION	CHANGE	Angle ± 3'			PROJ.	⌀	Customer NO.
				DIM TOL					

WCON
 Http: www.wcon.com

WCON-Dongguan Tel: +86 769 85358920 Fax: +86 769 85358915 E-mail: sales@wcon.com	WCON-Kunshan Tel: +86 512 57468408 Fax: +86 512 57468468 E-mail: salesks@wcon.com
---	--